



## Access Door Installation Instructions

# METAL FORM ACCESS DOOR INSTALLATION INSTRUCTIONS



Access Door Installation Instructions – October 1, 2024



# Access Door Installation Instructions

## TABLE OF CONTENTS

<b>I. General Overview and Information</b>	
A. Handling and Storage	Page 3
B. Door and Material Inspection	Page 3
<b>II. Cleaning and Maintenance</b>	
A. General Care and Cleaning	Page 3
B. Cleaning Access Doors	Page 3
<b>III. Construction Notes</b>	
A. Opening Verification	Page 4
B. Isolate Aluminum	Page 4
C. Thermal Pour & Debridge Pocket	Page 4
D. Blocking	Page 4
E. Sealant	Page 4
<b>IV. Door Installation</b>	
A. Door Rough Opening Verification	Page 5
B. Door Anchorage Fasteners	Page 5
C. Door Flange Sealant	Page 6
D. Door Insertion	Page 6
E. Door Anchorage Sequence	Page 7
F. Twin Door Notes	Page 7
<b>V. Final Door Inspection</b>	
A. Installer Quality Responsibility	Page 8
<b>VI. Maintenance Schedule for Access Doors</b>	
A. Frequent Maintenance	Page 9
B. Quarterly Maintenance	Page 9
C. Annual Maintenance	Page 9

**Completely read these Access Door Installation Instructions before beginning any work. These recommendations are for general installation procedures only. Actual job conditions may vary.**



# Access Door Installation Instructions

## I. General Overview and Information

### A. Handling and Storage

1. Handle all Access Doors carefully.
2. Do not drop, drag, or walk on boxed or crated material.
3. Place protective spacers between each door, doors and walls, and doors and floors during storage.
4. Do not stack door units at more than a 10° angle to prevent distortion.
5. Store doors off the ground on pallets, planks, or similar materials.
6. Protect doors from other trade damage or manufacturing processes with ventilated covering.
7. Remove material from packaging if it becomes wet. Repack materials and move to a dry location.

### B. Door and Material Inspection

1. Inspect all door and material upon delivery for damage and quantity accuracy. Report damage and/or missing material to Metal Form and freight carrier immediately.

## II. Cleaning and Maintenance

### A. General Care and Cleaning

1. Upon arrival to jobsite or facility, and prior to installation, the doors and hardware should be wiped down and cleaned.
2. Clean by soaking with clean water, then a mild soap solution to loosen any dirt, dust, or debris.
3. Use a non-abrasive or cloth brush to apply a non-abrasive cleanser to the door skin and material.
4. Use a squeegee or soft absorbent cloth to dry door skin prior to cleanser drying.
5. After door and frame is dry, a protective film may be applied to protect the door and components from new construction debris, dust, paint, welding spatter, or other contaminants.
6. All protective films must be reviewed for compatibility with finished door and components.
7. Do not hit, nick, or penetrate the door skin with any metal or sharp object.

### B. Cleaning Access Doors

1. Plaster, cement, terrazzo, alkaline, and acid based materials used to clean masonry are very harmful to painted and anodized finishes and should be removed with water and mild soap immediately to prevent permanent staining. Spot testing is recommended prior to any cleaning agent being applied to the doors.
2. Cleaning of painted aluminum and anodized aluminum surfaces should be performed in accordance with American Architectural Manufacturing Association (AAMA) 609 and 610-02 "Cleaning and Maintenance Guide for Architecturally Finished Aluminum."



# Access Door Installation Instructions

3. Galvanized steel cleaning: Remove debris and other materials that can scratch the metal from galvanized steel by rinsing with a hose or clean water. Remove water stains from galvanized steel with a hot water wash consisting of hot water and 1/4" cup of dish washing liquid. Use a soft bristle brush in small circular motions from one side to the other. To combat alkaline deposits on the galvanized steel mix a solution of 1 part baby powder and 2 parts milk together. Use a toothbrush or other small brush and scrub the surface of the metal. After galvanized steel has been washed, water stains removed, alkaline spots scrubbed away, rinse with clean, warm water. Rinse thoroughly so no soapy residue remains. Completely dry metal with soft cloth, do not leave moisture behind.
4. Clean stainless steel by using warm water and a cloth. After washing and wiping wet, dry with a towel or soft cloth to prevent water spots. Micro fiber cloths can be used and are a great option to clean stainless steel. If heavier dirt needs to be removed, a milder detergent or cleaning agent can be applied, ie. dish washing liquid. The stainless steel surface must be thoroughly rinsed to prevent staining and spotting. Towel dry any wet areas with a clean cloth to prevent water spots which can be caused by minerals or "hard water."

## III. Construction Notes

### A. Opening Verification

1. Ensure that construction that will receive the door is in accordance with the contract documents.
2. The rough opening must be verified to confirm it is square, level, and plumb, and has the proper clearance for the designated door.

### B. Isolate Aluminum

1. Aluminum that is in direct contact with masonry or incompatible materials must be isolated with a heavy coat of zinc chromate, plastic isolators, or bituminous paint.

### C. Thermal Pour & Debridged Pocket

1. Do not punch, penetrate, alter, or drill through the pour and debridged thermal break.

### D. Blocking

1. All blocking and shims should be non-corrosive or high strength plastic material (not supplied by Metal Form). Blocking must be of size to support the frame where indicated. The blocking must prevent the door frame from bowing, twisting, racking, or distorting.

### E. Sealant

1. All sealant used must be compatible with all the materials it contacts, including other sealant. All sealant, unless noted, is not by Metal Form and is to be supplied by others.

2. Metal Form does not recommend sealant or caulking types and will not assume liability or responsibility of sealant or caulking not supplied by Metal Form. The sealant supplier should be consulted for sealant recommendations associated with compatibility, adhesion, priming, tooling, shelf life, and joint design. It is the sole responsibility of the customer to perform all sealant adhesion and compatibility testing that is required by the sealant manufacturer of choice for sealant that is to be supplied by the customer.

## IV. Door Installation

### A. Door Rough Opening Verification

1. Door opening must be verified prior to installation of door in order for proper swing, operation, and performance to be achieved.
2. Check door opening to ensure it is square, level, and plumb.
3. Verify door opening dimension is sized to allow adequate clearance for installation of the door. Measure door frame dimension, width, and height to verify door will fit into door rough opening.
4. Door frame dimension is 1/4" less than the door opening dimension. This allows for 1/8" of clearance between door frame and opening on all four sides. (See Figure 1)
  - Clearance adjustments can be made on a job by job basis, but Metal Form must be notified and approve the deviation from our standard clearance dimension prior to proceeding with modified clearances.

### B. Door Anchorage Fasteners

1. Metal Form does not supply door anchor fasteners, nor does Metal Form recommend anchor fastener type or size.
2. If specified, Metal Form provides 5/16" perimeter frame anchorage at either 5-3/4" or 11-1/2" on center spacing.
3. Perimeter fasteners to be sized by the design engineer and provided by the installer.

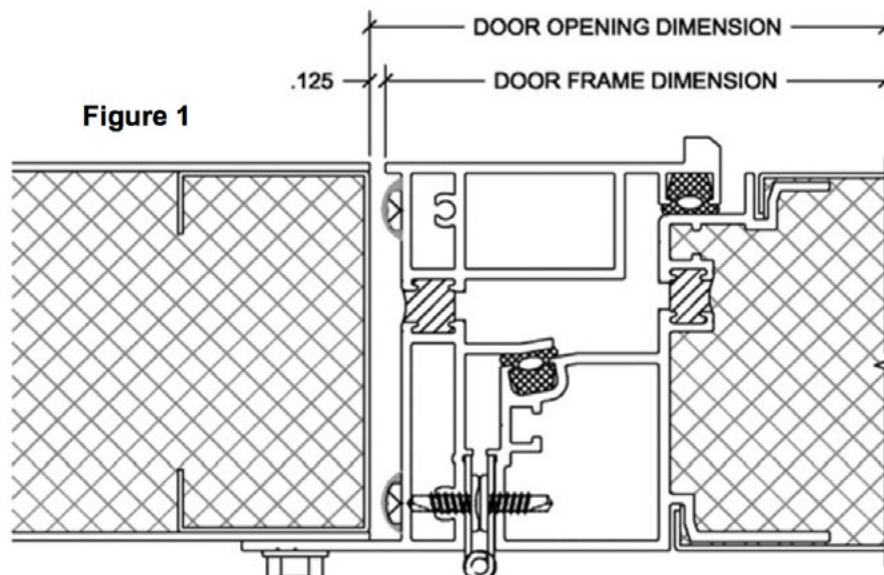

## C. Door Flange Sealant

1. Dry fit the door into the opening and block the door at the sill and jambs. Block it to be at 1/4 points.
2. Ensure the door is orientated correctly. The door will have a sticker indicating “Bottom Outside.” (See Figure 3)
  - Failure to install the Access Door with the correct orientation will result in door performance failure.
3. After door fit is confirmed, remove door from opening.
4. Apply a bead of sealant to all four sides of the interior side of the door flange. The bead should be applied in a line directly over the perimeter anchor fastener holes in the flange. (See Figure 2)
5. Apply a bead of sealant to all four mitered corners on the interior side of the door flange. Run the bead of sealant from the tip of the miter back to the main door frame body. (See Figure 2)

## D. Door Insertion

1. Reinsert the door into the door opening from the exterior. Sealant on door flange outline in steps 1-2 on Section C is to be wet when door is installed into the opening. (See Figure 4, page 7)
2. Block the door hard to the opening at the sill and jambs. This blocking is to be at 1/4 points.
3. Tool and clean excess sealant that is squished out between the door flange and door opening condition.
4. **Installer Note:** The door should be installed plumb, level, and true to ensure door swings properly and meets all performance criteria. See Section V.

Figure 2

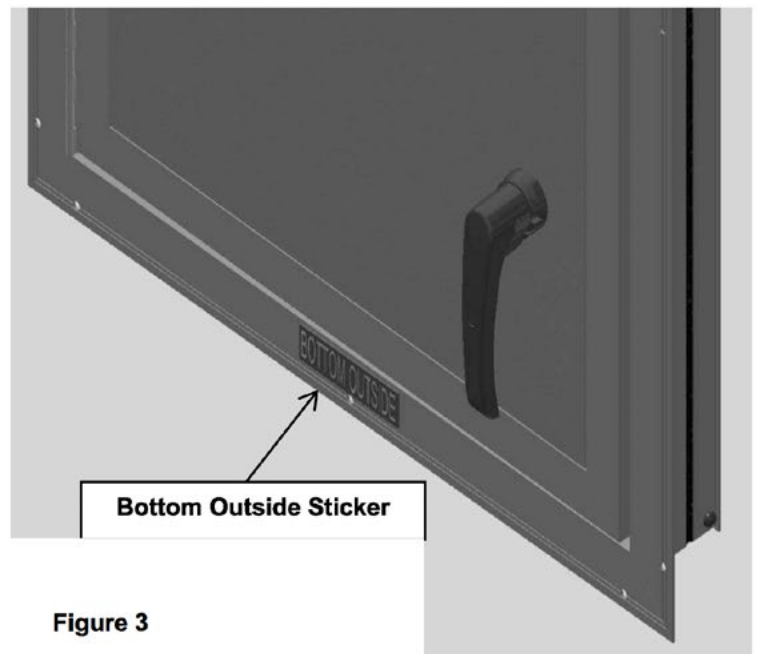
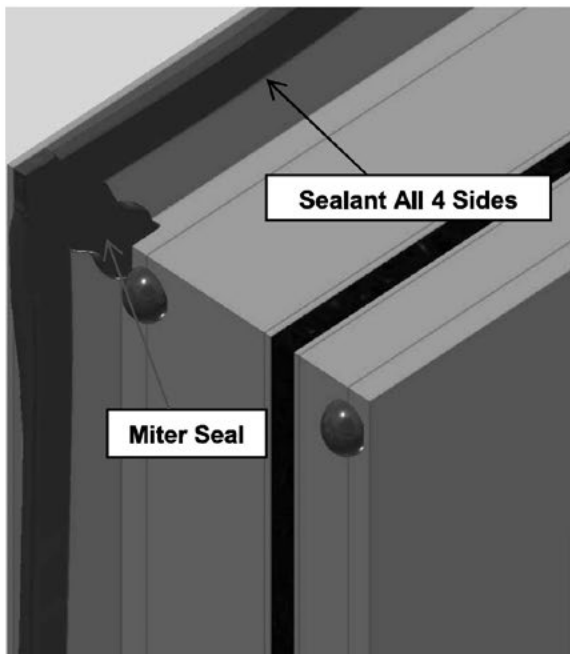

Figure 3

## E. Door Anchorage Sequence

1. The door anchor fasteners must be installed in a specific sequence. (See Figure 5)
2. After anchor #2 is installed, check the door to ensure it is still plumb and level.
3. After anchor #4 is installed, check the door to ensure it is still square.
4. Open door to 90 degrees after anchor #6 and anchor all remaining locations on the hinge side.
5. Anchor #7 and #8 with the door open.
6. Close and reopen door after anchor #8 and verify door operates smoothly.
7. Recheck door to confirm it is level and square.
8. Visually check the reveal on the opposite side of the door, between door frame and opening.
9. Install remaining anchor fasteners at all remaining locations.
10. Remove bottom outside sticker after door is fully anchored.

## F. Twin Door Notes

1. The twin door is to be blocked at the mullion location at the head and sill as well as at 1/4 points as outlined in Section D step 5.

Figure 4

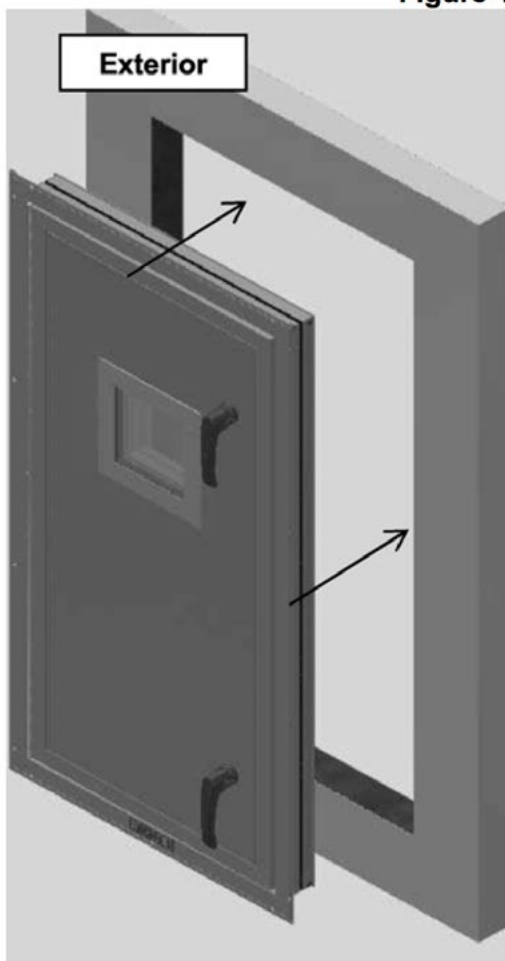

Figure 5



## V. Final Door Inspection

### A. Installer Quality Responsibility

1. Ensure door is installed plumb, level, and true.
2. Ensure doors have consistent reveals at all four sides after installation.
3. Check swing operation of door.
  - Door should operate smoothly and without interference.
4. Ensure door frames are not rolled in or out. Door frames are to be square. Block door as outlined in Section IV, part D, #5.
5. Adjust all hardware on doors to ensure door panel is flush with frame. (See Figure 6)  
After necessary hardware adjustments have been made, check hardware to ensure proper operation and performance.
6. Inspect door gaskets for any damage that may have occurred during storage, installation, or other construction. Ensure door gasket is seated in gasket raceway.
7. Visually inspect finish and remove any debris.
8. Open and close door to check proper swing, clearance, and operation.
9. Visually check exterior perimeter caulking and repair as needed.
10. **Failure to check the above installation areas or install the door per these Installation Instructions could result in door performance failures.**

Figure 6

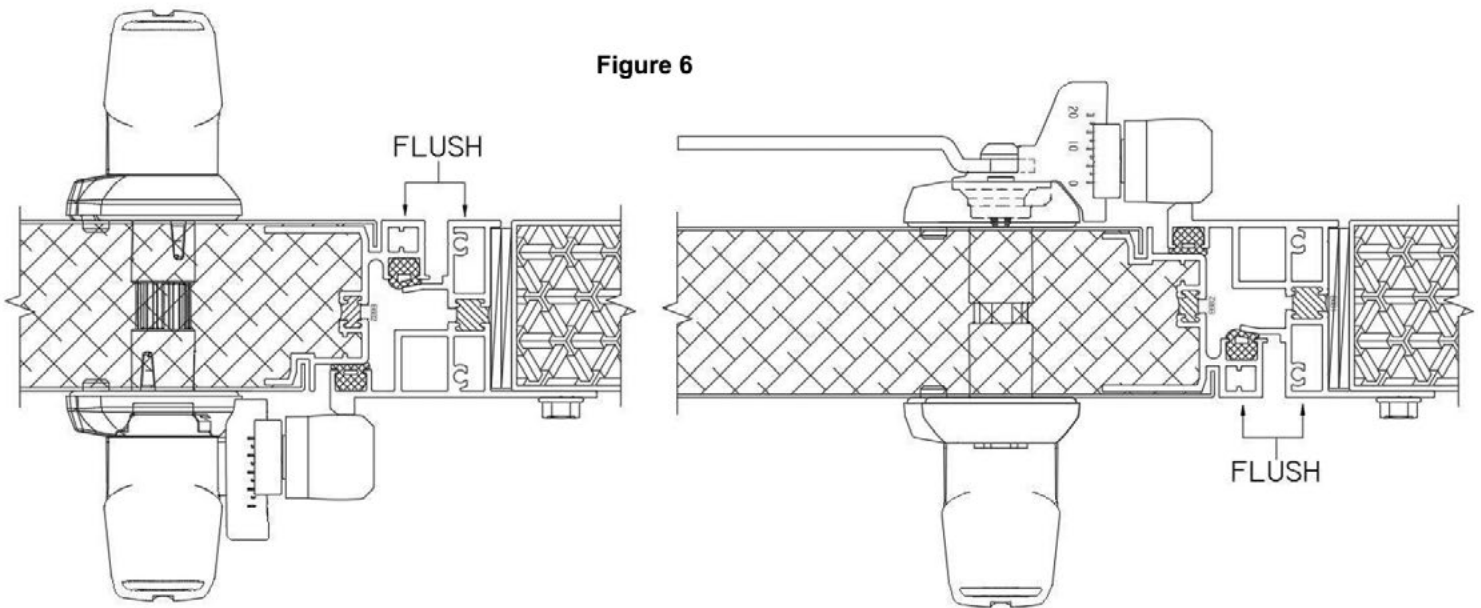



# Access Door Installation Instructions

## VI. Maintenance Schedule for SD Doors

### A. Frequent Maintenance

1. Visually check exterior perimeter caulking and repair as needed.
2. Check hardware to ensure proper engagement, operation, and performance.
3. Open and close door for proper swing and clearance operation.
4. Visually inspect finish and remove any debris.
5. Visually inspect internal door gaskets for any damage that may have occurred during door usage.

### B. Quarterly

1. Blow or vacuum out dust, dirt, and all debris from within the door frame and viewports.
2. Remove any debris within the door system, attached to gaskets, or stuck to door leaf as it may cause deficiency in hardware operation, performance, and finish.
3. Clean sand and debris from all working mechanisms, hinges, latches, roller, viewports, and any specialty parts.
4. Check exterior perimeter caulking and repair as needed.
5. Adjust hardware to ensure proper engagement, operation, and performance.

### C. Annually

1. Check anchors for any movement or detachment due to normal expansion and contraction of materials.
2. Check internal door gaskets for cuts, cracking, or damage.